

PBD型直动式溢流阀

PBD DIRECT OPERATED PRESSURE RELIEF VALVES

符号 SYMBOL

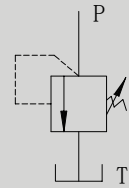

PBD型溢流阀是直动式座阀，用以限制系统压力，其结构可分为锥阀（压力至40Mpa）和球阀结构，压力等级分别为2.5；5；10；20；31.5；40。

该阀体积小、结构紧凑、流量特性好、噪音小、压力稳定、广泛应用在小流量系统中，可作为安全阀及遥控阀等。

PBD series relief valves are direct operated poppet type used to limit pressure in a hydraulic system. The design can be divided into poppet (Max.40Mpa) and ball type. There are six pressure adjustment ranges available 2.5;5;10;20;31.5;40Mpa. It has characteristics of compact structure,high performance, reliable work, low noise and long service life. These series are widely applied to many lower flow systems, can be also used as relief valve and remote control valve, etc.

▶ 技术参数 Technical data

口径 Size		6	8	10	15	20	25	30
工作压力(Mpa) Operating pressure(Mpa)		31.5						
最大流量(L/min) Max .flow rate(L/min)		35	60	80	150	200	250	300
介质温度(°C) Fluid temperature(°C)		-20 ~ 70						
过滤精度(μ m) Filtration accuracy(μ m)		25						
重量(千克) Weight(KGS)	PBD K	0.4		0.5		0.9		2.1
	PBD G	1.6	3.6	3.6	6.9	6.9	15.2	15.2
	PBD P	1.7		3.7		7.1		15.7
阀体 (材料) 表面处理 Valve body (Material) Surface treatment		钢件 表面发黑处理 Steel Body Surface Black Oxide						
油液清洁度/Oil cleanliness		NAS1638 9级和ISO4406 20/18/15级 NAS1638 class 9 and ISO4406 class 20/18/15						

CADIRIRI
www.cadiriri.com.br
formularios@cadiriri.com.br
 (11) 2601-2839
 (11) 96393-2796

▶ 特性曲线 (在使用 HLP46 , 油=40°C ± 5°C时测得)
 Characteristic curves (measured with HLP46, Voil=40°C ± 5°C)

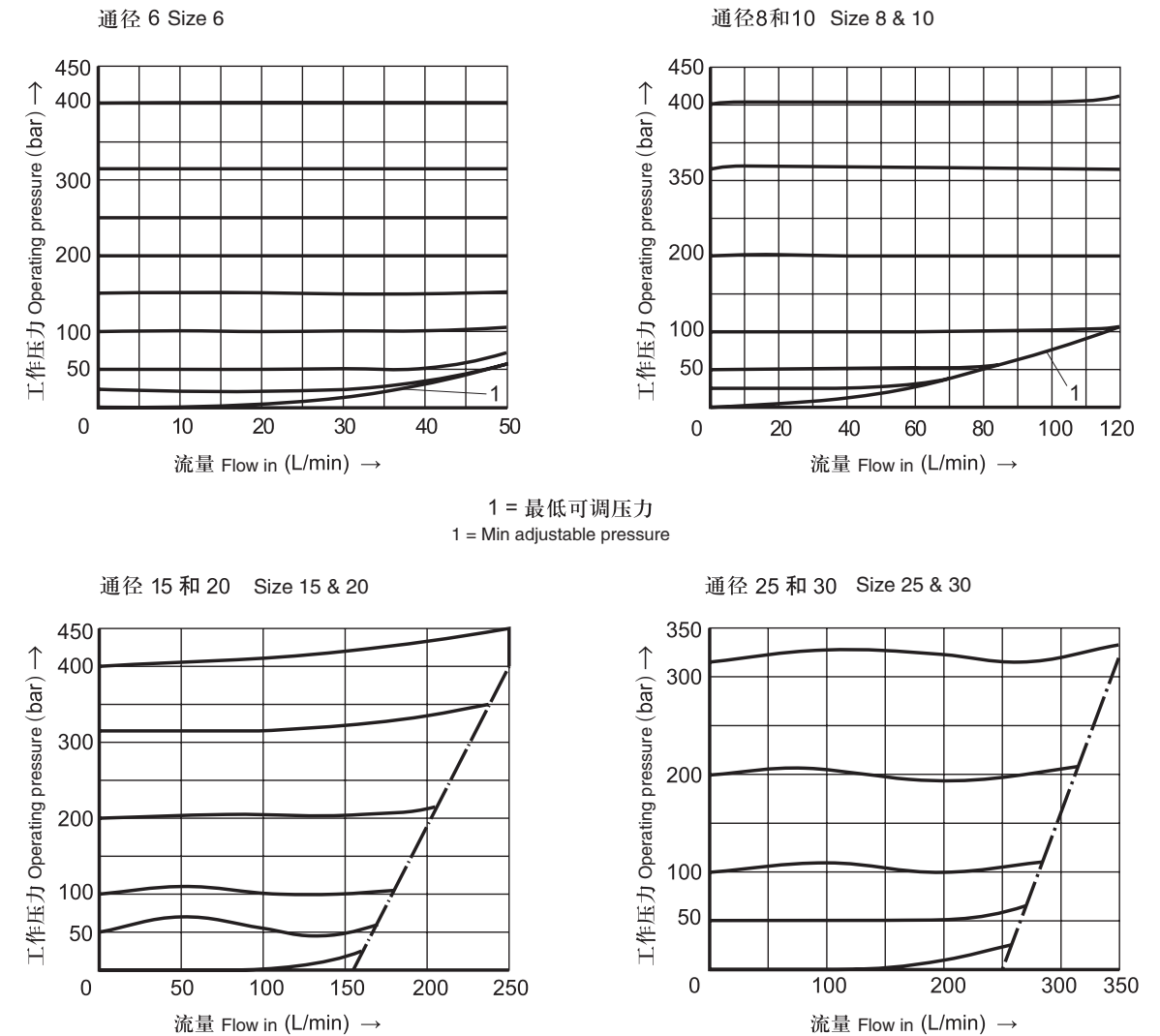

⚠ 注意!

- 该性能曲线在整个流量范围内对出口压力=0有效，且在测量时不考虑壳体内部的压降!
- 特性曲线仅在所述环境和温度条件下有效。必须考虑特性曲线受边界条件变化的影响!

⚠ Attention!

- The curves are available when output pressure =0 within the flow ranges, and the pressure differential of housing is not considered when measures.
- The curves are only available for the said environment and temperature conditions,and the effect of boundary variation conditions for characteristic curves must be considered.

- 该性能曲线与给定压力等级（如200bar）相关联。在其他离开额定压力等级的压力设定值时（如<200bar时），随着溢流流量的增加压力的升高值会更大一些。

- The curves are related to setting pressure level (like 200bar.).The increased pressure data will be higher when relief flow rate added.

PBD*K插入阀连接尺寸 PBD*K Dimensions for cartridge

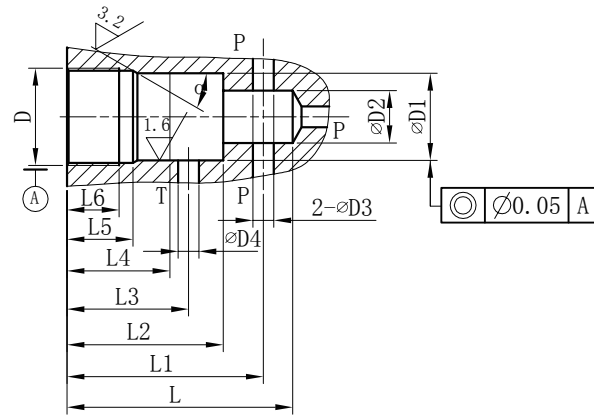

口径 Size	D	D1	D2	D3	D4	L	L1	L2	L3	L4	L5	L6	α
6	M28x1.5	25H8	15	6	6	65	56.5 ± 1	45	35	30	19	15	15°
10	M35x1.5	32H8	18.5	10	10	80	67.5 ± 1	52	41	35	23	18	15°
20	M45x1.5	40H8	24	20	20	110	91.5 ± 1	70	54	45	27	21	20°
30	M60x2	55H8	38.75	30	30	140	113.5 ± 1	84	60	45	29	23	20°

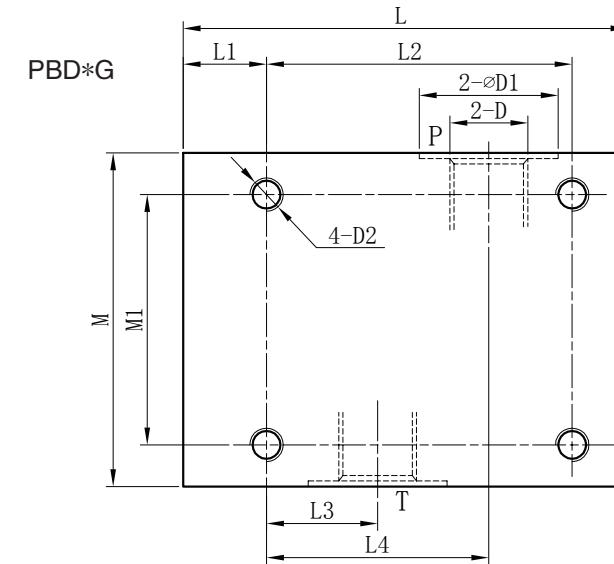

口径 Size	D		L	L1	L2	L3	L4	M	M1	D1	D2
	英制 Inch	公制 Metric									
6	G 1/4"	M14 × 1.5	80	15	55	20	40	60	45	25	M6/15
(8)10	(G 3/8") G1/2"	(M18X1.5) M22X1.5	100	20	70	21	49	80	60	(28) 34	M8/15
(15)20	(G 3/4") G1"	(M27X2) M33X2	135	20	100	34	65	100	70	(42) 47	M8/22
(25)30	(G1 1/4") G1 1/2"	(M42X2) M48X2	180	25	130	35	85	130	100	(56) 61	M10/22

安装尺寸/Installation dimensions

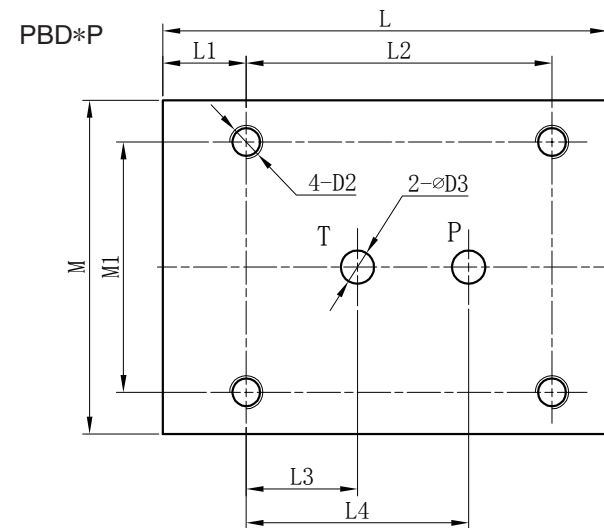

口径 Size	L	L1	L2	L3	L4	M	M1	D2	D3
6	80	15	55	20	40	60	45	M6/15	6
10	100	20	70	21	45	80	60	M8/15	10
20	135	20	100	34	65	100	70	M8/22	20
30	180	25	130	35	85	130	100	M10/22	30



型号: 直动式
Direct operated

S = 带保护罩的调节螺栓
H = 带手轮
S = Adjustable screw and protective cap
H = Handwheel

口径 6(8)10(15)20(25)30
Size 6(8)10(15)20(25)30

K = 插入式; G = 管式; P = 板式
K = Cartridge valve
G = Threaded connection
P = Subplate mounting

无 = 丁晴橡胶
V = 氟橡胶
No code = NBR seals
V = FPM seals

无 = 英制; 2 = 公制
No code = Inch thread; 2 = metric
压力等级(兆帕): 2.5; 5; 10; 20; 31.5; 40
Pressure range(MPa): 2.5; 5; 10; 20; 31.5; 40

系列号10系列(压力等级2.5 ~ 40 MPa)
Series No.10 (Pressure rating 2.5 ~ 40 MPa)